

NOMENCLATOR TIP ROBINETI DE DIRIJARE MODEL EKY

1. SIMBOLIZARE

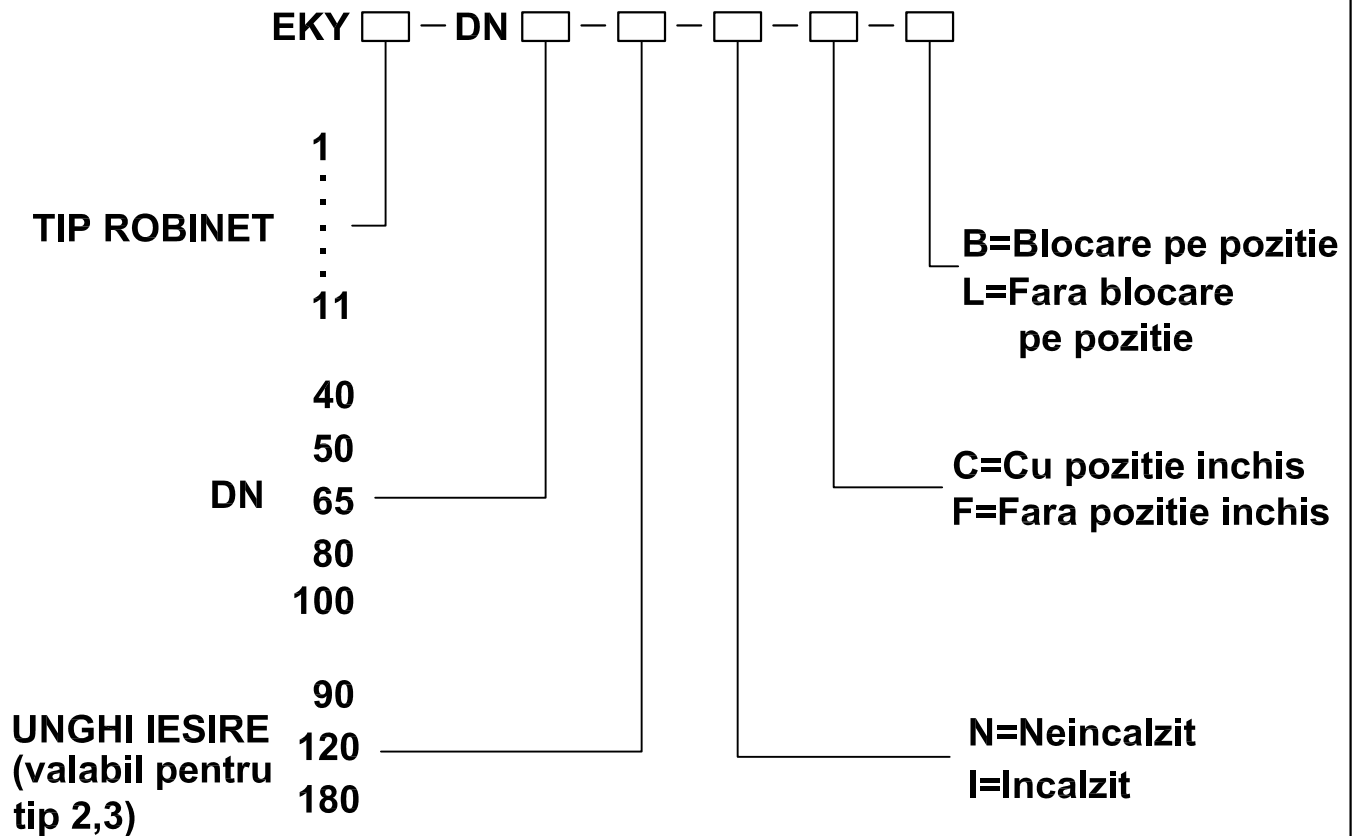





NOTA:

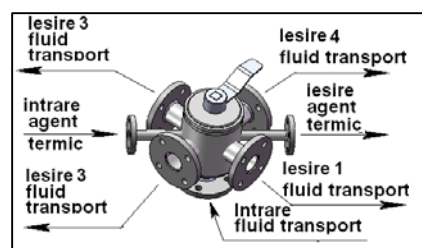
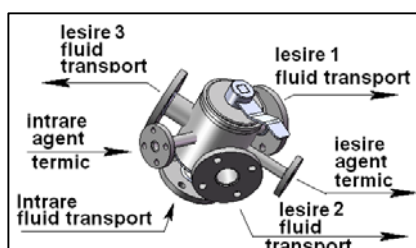
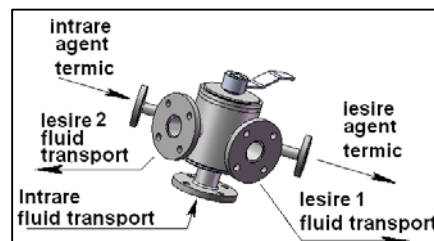



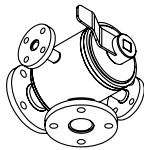
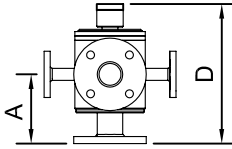

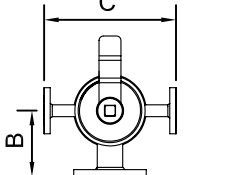



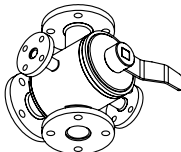
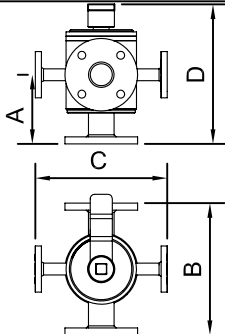
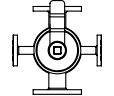

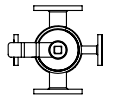
Optional pot fi echipate cu :

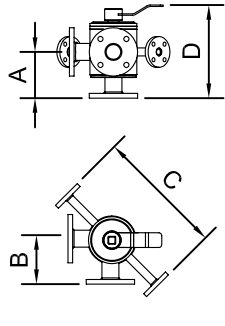
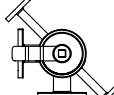

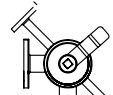

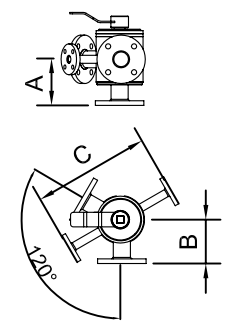
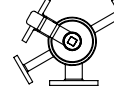

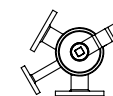

- actionare servomotor
- actionare pneumatica
- senzor de pozitie
- senzor temperatura (termostat)

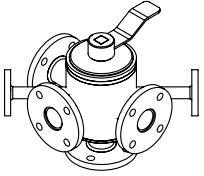
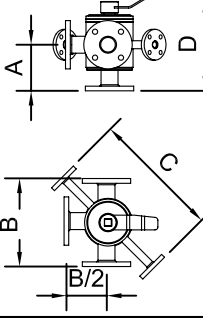
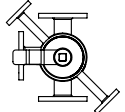

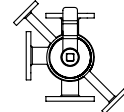

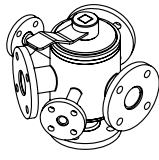
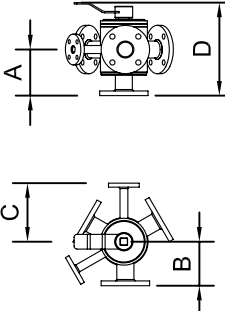
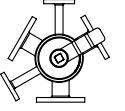

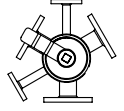



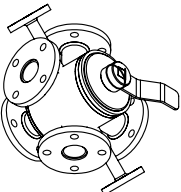
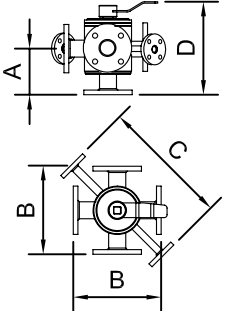
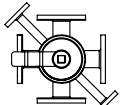

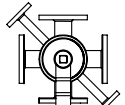

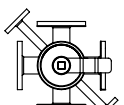

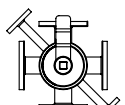

2. Fisa tehnica robineti de trecere incalziti

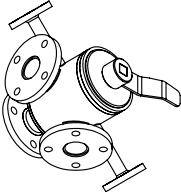
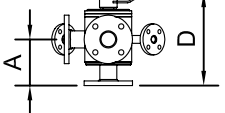
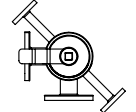
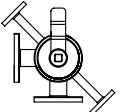

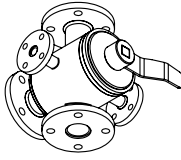
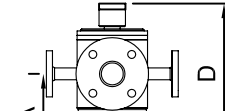
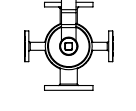
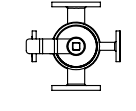

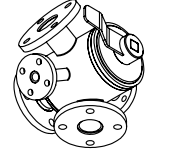
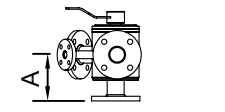



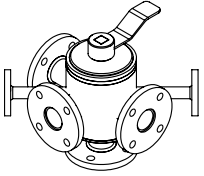
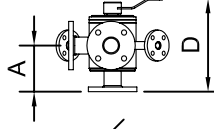
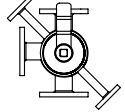

Tip robinet		DN	Dimensiuni gabarit		Pozitii de lucru	
EKY 1		40	A=114 C=254	B=114 D=280		 Inchis
		50	A=114 C=254	B=114 D=280		
		65	A=165 C=290	B=162.5 D=390		 Deschis
		80	A=165 C=350	B=187.5 D=390		
		100	A=190 C=350	B=187.5 D=440		

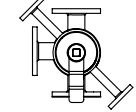

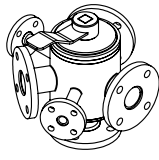
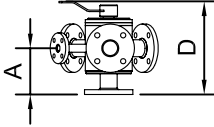
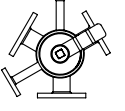

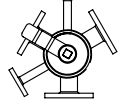

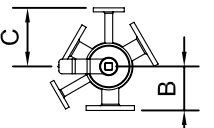
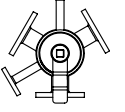



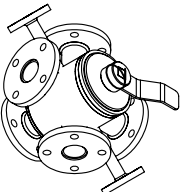
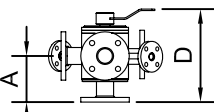
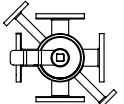

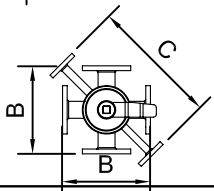
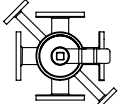
Tip robinet		DN	Unghi iesire	Dimensiuni gabarit		Pozitii de lucru				
EKY 2		40	180°	A=114	B=228					
		50		C=254	D=280					
		65		A=114	B=228					
		80		C=254	D=280					
		100		A=165	B=325					
	40	90°	A=114	B=114						
	50		C=254	D=280						
	65		A=165	B=162.5						
	80		C=290	D=390						
	100		A=165	B=187.5						
	40	120°	A=114	B=114						
	50		C=254	D=280						
	65		A=165	B=162.5						
	80		C=290	D=390						
	100		A=165	B=187.5						
				A=190	B=375					
				C=350	D=440					
				A=114	B=114					
				C=254	D=280					
				A=114	B=114					
				C=254	D=280					
				A=165	B=162.5					
				C=290	D=390					
				A=165	B=187.5					
				C=350	D=390					
				A=190	B=187.5					
				C=350	D=440					

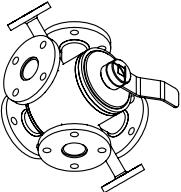
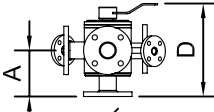
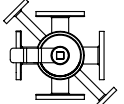
Tip robinet		DN	Unghi iesire	Dimensiuni gabarit		Pozitii de lucru					
EKY 3		40	90°	A=114	B=268			Deschis			
		50		A=114	B=268						
		65		A=165	B=325						
		80		A=165	B=375						
		100		A=190	B=375						
		40	120°	A=114	B=114			Deschis			
		50		A=114	B=114						
		65		A=165	B=162.5						
		80		A=165	B=187.5						
		100		A=190	B=187.5						

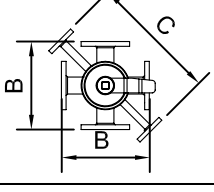
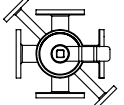
Tip robinet		DN	Dimensiuni gabarit		Pozitii de lucru					
EKY 4		40	A=114	B=268		 Deschis		 Deschis		Nu are pozitie inchis
		50	A=114	B=268						
		65	A=165	B=325						
		80	A=165	B=375						
		100	A=190	B=375						
			C=404	D=280	 Deschis		 Deschis			
			C=460	D=390						
			C=485	D=390						
			C=485	D=440						

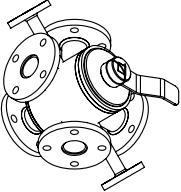
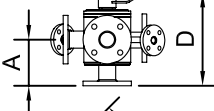
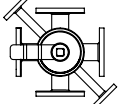

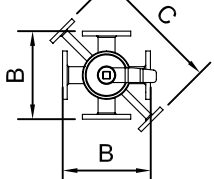
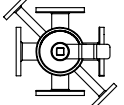

Tip robinet		DN	Unghi iesire	Dimensiuni gabarit		Pozitii de lucru				
EKY 5		40	90°	A=114	B=114			Deschis		
		50		C=254	D=280					
		65		A=114	B=114					
		80		C=254	D=280					
		100		A=165	B=162.5					
		40	180°	A=114	B=228			Deschis		
		50		C=254	D=280					
		65		A=114	B=228					
		80		C=254	D=280					
		100		A=165	B=325					
		40	120°	A=114	B=114			Deschis		
		50		C=254	D=280					
		65		A=114	B=114					
		80		C=254	D=280					
		100		A=165	B=162.5					
				A=165	B=187.5					
				C=290	D=390					
				A=165	B=187.5					
				C=350	D=390					
				A=190	B=187.5					
				C=350	D=440					
				A=165	B=375					
				C=350	D=390					
				A=190	B=375					
				C=350	D=440					
				A=114	B=114					
				C=254	D=280					
				A=114	B=114					
				C=254	D=280					
				A=165	B=162.5					
				C=290	D=390					
				A=165	B=187.5					
				C=350	D=390					
				A=190	B=187.5					
				C=350	D=440					





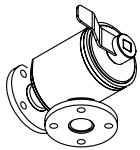
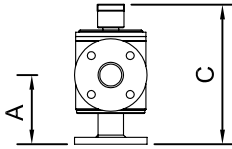

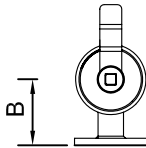



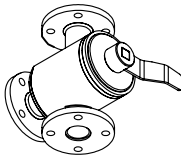
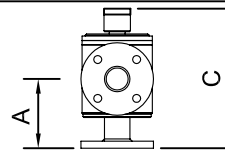



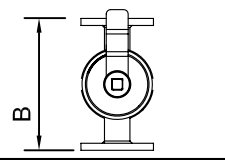

Tip robinet		DN	Unghi iesire	Dimensiuni gabarit		Pozitii de lucru				
EKY 6		40	90°	A=114	B=268					
		50		C=404	D=280					
		65		A=165	B=325					
		80		A=165	B=375					
		100		A=190	B=375					
		40	120°	A=114	B=114					
		50		C=127	D=280					
		65		A=165	B=162.5					
		80		A=165	B=187.5					
		100		A=190	B=187.5					
				C=175	D=440				Nu are pozitie inchis	

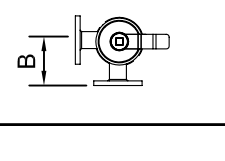

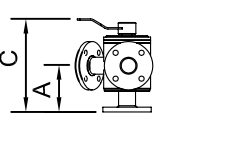



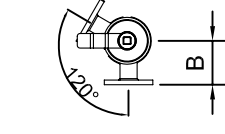



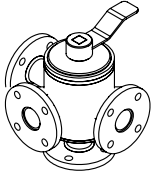
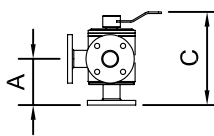

Tip robinet		DN	Dimensiuni gabarit		Pozitii de lucru					
EKY 7		40	A=114 C=404	B=268 D=280			Deschis		Deschis	Nu are pozitie inchis
		50	A=114 C=404	B=268 D=280						
		65	A=165 C=460	B=325 D=390			Deschis		Deschis	
		80	A=165 C=485	B=375 D=390						
		100	A=190 C=485	B=375 D=440						
EKY 8		40	A=114 C=404	B=268 D=280			Deschis		Deschis	Nu are pozitie inchis
		50	A=114 C=404	B=268 D=280						
		65	A=165 C=460	B=325 D=390			Deschis		Deschis	
		80	A=165 C=485	B=375 D=390						
		100	A=190 C=485	B=375 D=440						
EKY 9		40	A=114 C=404	B=268 D=280			Deschis		Deschis	Nu are pozitie inchis
		50	A=114 C=404	B=268 D=280						
		65	A=165 C=460	B=325 D=390			Deschis		Deschis	
		80	A=165 C=485	B=375 D=390						
		100	A=190 C=485	B=375 D=440						

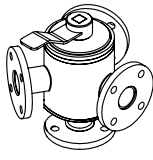
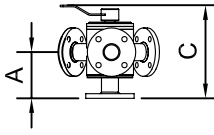

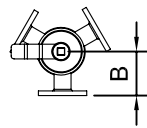

Tip robinet		DN	Dimensiuni gabarit		Pozitii de lucru				
EKY 10		40	A=54	B=228			Deschis		
		50	A=54	B=228					
		65	A=75	B=325			Deschis		
		80	A=75	B=375					
		100	A=100	B=375					
EKY 11		40	A=54	B=228			Deschis		
		50	A=54	B=228					
		65	A=75	B=325			Deschis		
		80	A=75	B=375					
		100	A=100	B=375					





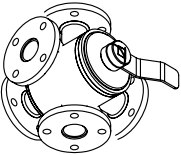
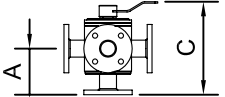

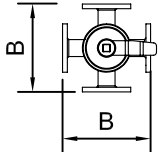



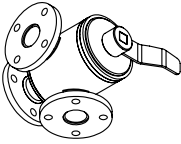
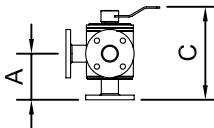

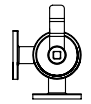

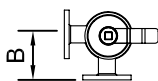

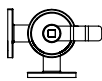

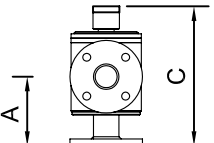



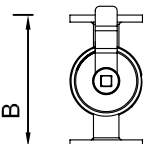

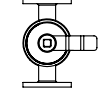
3. Fisa tehnica robineti de trecere neincalziti

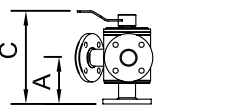



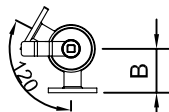





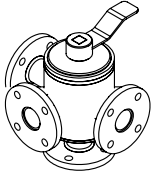
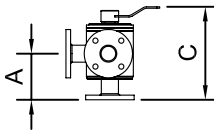
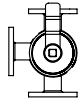

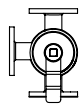

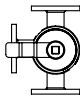
Tip robinet		DN	Dimensiuni gabarit		Pozitii de lucru	
EKY 1		40	A=114 C=280	B=114		 Inchis
		50	A=114 C=280	B=114		
		65	A=165 C=390	B=162.5		 Deschis
		80	A=165 C=390	B=187.5		
		100	A=190 C=440	B=187.5		

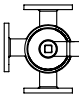

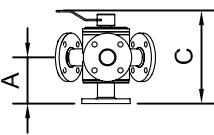





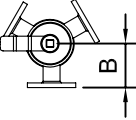

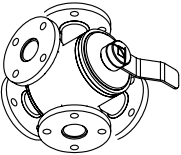
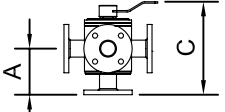
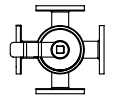

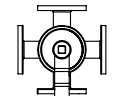

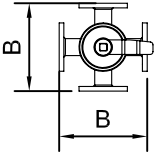
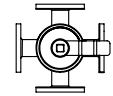

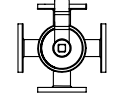

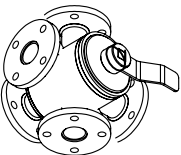
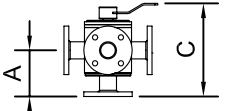
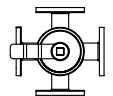

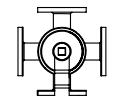

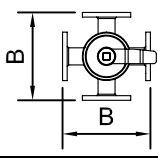
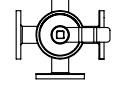

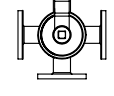
Tip robinet		DN	Unghi iesire	Dimensiuni gabarit		Pozitii de lucru					
EKY 2		40	180°	A=114 C=280	B=228			Deschis			
		50		A=114 C=280	B=228						
		65		A=165 C=390	B=325						
		80		A=165 C=390	B=375						
		100		A=190 C=440	B=375			Deschis			
	40	A=114 C=280	B=114								
	50	A=114 C=280	B=114								
	65	A=165 C=390	B=162.5								
	80	A=165 C=390	B=187.5								
	100	A=190 C=440	B=187.5			Deschis					
	40	A=114 C=280	B=114								
	50	A=114 C=280	B=114								
	65	A=165 C=390	B=162.5								
	80	A=165 C=390	B=187.5								
	100	A=190 C=440	B=187.5			Deschis					
40	A=114 C=280	B=114									
50	A=114 C=280	B=114									
65	A=165 C=390	B=162.5									
80	A=165 C=390	B=187.5									
100	A=190 C=440	B=187.5			Deschis						

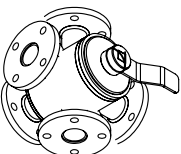
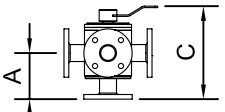
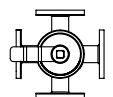

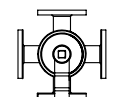

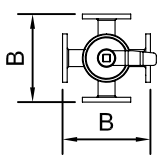
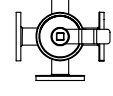

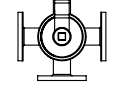



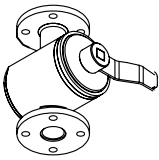
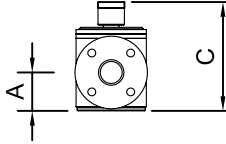



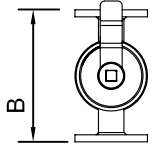









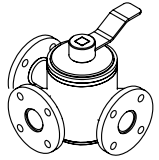
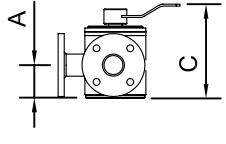

Tip robinet		DN	Unghi iesire	Dimensiuni gabarit		Pozitii de lucru				
EKY 3		40	90°	A=114	B=268		 Deschis		 Deschis	
		50		A=114	B=268					
		65		A=165	B=325					
		80		A=165	B=375					
		100		A=190	B=375					
		40	120°	A=114	B=114		 Deschis		 Deschis	
		50		A=114	B=114					
		65		A=165	B=162.5					
		80		A=165	B=187.5					
		100		A=190	B=187.5					
						 Deschis		 Deschis		

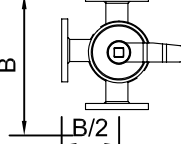
Tip robinet		DN	Dimensiuni gabarit		Pozitii de lucru				
EKY 4		40	A=114 C=280	B=268			Deschis		Nu are pozitie inchis
		50	A=114 C=280	B=268					
		65	A=165 C=390	B=325			Deschis		
		80	A=165 C=390	B=375					
		100	A=190 C=440	B=375					

Tip robinet		DN	Unghi iesire	Dimensiuni gabarit		Pozitii de lucru				
EKY 5		40	90°	A=114 C=280	B=114					
		50		A=114 C=280	B=114					
		65		A=165 C=390	B=162.5					
		80		A=165 C=390	B=187.5					
		100		A=190 C=440	B=187.5					
	40	A=114 C=280	B=228							
	50	A=114 C=280	B=228							
	65	A=165 C=390	B=325							
	80	A=165 C=390	B=375							
	100	A=190 C=440	B=375							
	40	A=114 C=280	B=114							
	50	A=114 C=280	B=114							
	65	A=165 C=390	B=162.5							
	80	A=165 C=390	B=187.5							
	100	A=190 C=440	B=187.5							

Tip robinet		DN	Unghi iesire	Dimensiuni gabarit		Pozitii de lucru					
EKY 6		40	90°	A=114 C=280	B=268						
		50		A=114 C=280	B=268						Deschis
		65		A=165 C=390	B=325						
		80		A=165 C=390	B=375						
		100		A=190 C=440	B=375						
	40	120°	A=114 C=280	B=114	Deschis						
	50		A=114 C=280	B=114					Nu are pozitie inchis		
	65		A=165 C=390	B=162.5							
	80		A=165 C=390	B=187.5							
	100		A=190 C=440	B=187.5							

Tip robinet		DN	Dimensiuni gabarit		Pozitii de lucru						
EKY 7		40	A=114 C=280	B=268			Deschis				Nu are pozitie inchis
		50	A=114 C=280	B=268							
		65	A=165 C=390	B=325			Deschis				
		80	A=165 C=390	B=375							
		100	A=160 C=440	B=375							
EKY 8		40	A=114 C=280	B=268			Deschis				Nu are pozitie inchis
		50	A=114 C=280	B=268							
		65	A=165 C=390	B=325			Deschis				
		80	A=165 C=390	B=375							
		100	A=190 C=440	B=375							
EKY 9		40	A=114 C=280	B=268			Deschis				Nu are pozitie inchis
		50	A=114 C=280	B=268							
		65	A=165 C=390	B=325			Deschis				
		80	A=165 C=390	B=375							
		100	A=190 C=440	B=375							

Tip robinet		DN	Dimensiuni gabarit		Pozitii de lucru										
EKY 10		40	A=54 C=220	B=228											
		50	A=54 C=220	B=228							Deschis		Inchis		
		65	A=75 C=390	B=325	Deschis		Inchis								
		80	A=75 C=300	B=375											
		100	A=100 C=350	B=375	Deschis		Inchis								
EKY 11		40	A=54 C=220	B=268											
		50	A=54 C=220	B=268							Deschis		Deschis		
		65	A=75 C=300	B=325	Deschis		Inchis								
		80	A=75 C=300	B=375											
		100	A=? C=350	B=375	Deschis		Inchis	